

Full Color Sorting

OPTICAL SORTER

REZS4500・6500DIS / AIS / BI



REZS6500DIS

Satake's all new full color optical sorter will provide you the best solution in color sorting.

1) Full Color Camera

The machine is equipped with Japan's latest full color camera which recognizes the target just like the human eyes do. Even slight color differences such as light yellow grain can be detected.

2) Automatic defect profiling

The machine incorporates advanced software to evaluate color profile of target defects and automatically creates the sensitivity settings.

3) LED Lighting

LED lighting is applied for optical section to maintain good performance and also long lifetime will reduce machine's running cost.

4) New Ejector Pitch for Precise Sorting

Advance ejector valve pitch 5mm can provide more precise sorting, and it is effective to reduce percentage of good grain in final rejected.

5) Three Stage Sorting System

Precise sorting is achieved with three stage sorting system. Rejects from primary-sort will be sorted twice to minimize product loss(REZS4000 only).

Comparison of Sensing

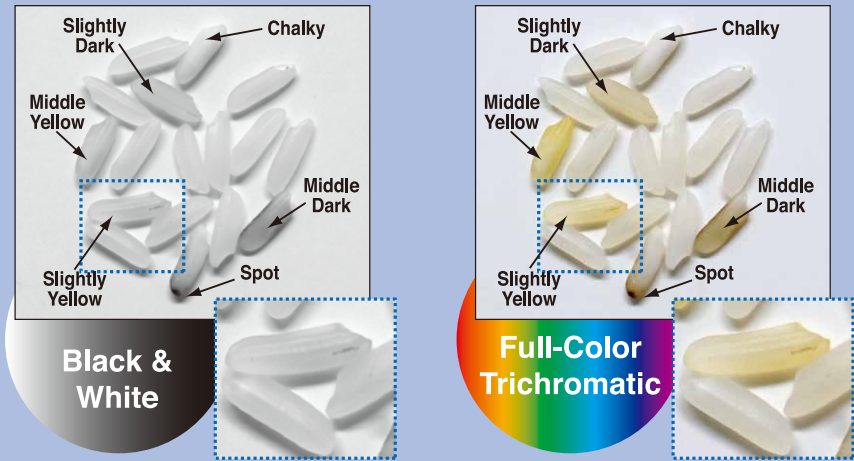

Advanced Color Touch Screen



Easy to use flick scroll

LED Lighting



Long Lifetime, Good Performance

Dimensions(mm) & Specifications

Model	REZS4500			REZS6500		
	DIS	AIS	BI	DIS	AIS	BI
Chute Width & Nos.	224mm x 4pcs 146mm x 2pcs 137mm x 1pc	224mm x 4pcs 224mm x 2pcs	224mm x 6pcs	224mm x 6pcs 224mm x 2pcs 224mm x 1pc	224mm x 6pcs 224mm x 3pcs	224mm x 9pcs
Output Capacity(Long grain white rice)*	5-7t/h		7-10t/h	7.5-10.5t/h		10.5-13.5t/h
Ejector Pitch	5mm					
Air Compressor	15-22kW			22-30kW		
Power Supply	Single Phase 200 - 240V					

* 3-5% Contamination. Sorting performance varies depending on variety, condition of material, and initial contaminations.

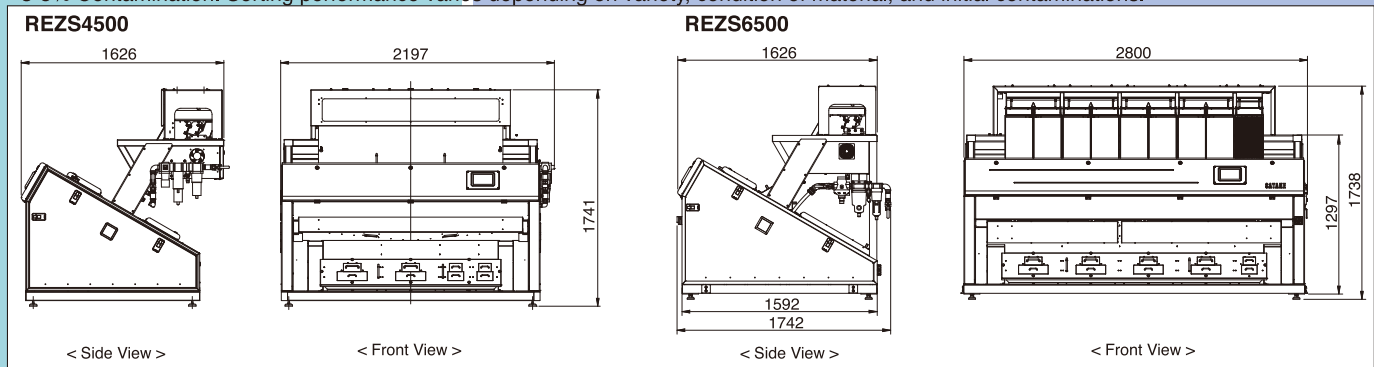

All Satake products are the subject of continuous development and, as a result, their specification may change and differ in detail from those shown.

SATAKE CORPORATION

Head Office
2-30 Saijo Nishihonmachi,
Higashi-Hiroshima-shi, Hiroshima-ken,
739-8602, Japan
URL : www.satake-group.com

SATAKE USA INC.
10900 Cash Road,
Stafford, Texas, 77477, U.S.A.
URL : www.satake-usa.com

SATAKE AMERICA LATINA LTDA.
Rua Xavantes, 155-Pav. 20, Bairro
Atiradores, CEP 89203-210, Joinville,
Santa Catarina, Brazil
URL : www.satake.com.br/

SATAKE EUROPE LTD.
P.O. Box 53, Horsfield Way, Bredbury
Industrial Park, Bredbury, Stockport,
Cheshire, SK6 2SU, U.K.
URL : www.satake-europe.com

SATAKE INDIA ENGINEERING PVT. LTD.
4th Floor, Tower-1, HB Twin Towers, A2,
3, 4, Netaji Subhash Place, Wazirpur
District Centre, New Delhi, 110034, India
URL : www.satakeindia.com/

SATAKE (THAILAND) CO., LTD.
133,134 Moo 5, Bangkadi, Mueang
Pathum Thani, Pathum Thani 12000,
Thailand
URL : www.sataketh.com

SATAKE INTERNATIONAL BANGKOK CO., LTD.
888/84 Mahatun Plaza Bld., 8th Floor,
Ploenchit Rd., Lumpini, Pathumwan,
Bangkok, 10330, Thailand
URL : www.sataketh.com

PT. SATAKE GOBEL INDONESIA
Gedung Surabaya Bumi Mandiri,
Lantai 9, Jalan Jenderal Basuki
Rachmat Nomor 129-137, Unit 905 B,
Indonesia

SATAKE MANUFACTURING (SUZHOU) CO., LTD.
229 Jin Feng Road, Suzhou New
District, Suzhou, Jiangsu Province,
215129, China
URL : www.satake.cn/

SATAKE AUSTRALIA PTY. LTD.
15 Leland Street, Penrith, N.S.W.,
2750, Australia
URL : www.satake.com.au

ISO 9001 Certification
(Quality Management Systems)

ISO 14001 Certification
(Environmental Management Systems)

SATAKE CORPORATION has obtained ISO9001 and ISO14001 certification. These international standards for management systems ensure Satake will continue to provide high quality products and services.